

**HDMI over CAT5e/6/7 Wall Plate (Slimline)
Transmitter w/ 48V PoH - # 15496/7**



Operation Manual

Introduction

This HDMI and Audio over Single CAT5e/6/7 Wall-Plate Transmitter and Receiver set can send uncompressed audio/video along with controls, IP and USB data over a single run of CAT5e/6/7 cable up to 100m. It has the added benefit of control through the built-in RS-232 and IR ports. With LAN serving connection and external digital and analog audio capability that gives users the convenience of additional audio connection. This system also allows the connection of any USB host, enabling a USB connection to up to 2 USB ports, giving the Receiver the ability to act like a USB hub. The 48V PoH design can power the Receiver (PD) from the Transmitter (PSE), eliminating the need for a separate power supply for the Receiver.

Applications

- 48V PoH from Transmitter (PSE) to Receiver (PD)
- Household entertainment extending and control
- Lecture room display and control
- Showroom display and control
- Meeting room presentation and control
- Classroom display and control

Features

- Supports HDBaseT 2.0 specification supporting over a single CAT6/7 cable up to 100m/328ft and CAT5e cable up to 90m/295ft
- Receiver features 2 USB 2.0 ports
- HDMI (with 3D & 4K2K 60_YUV420 support), HDCP 2.2 and DVI compatible
- HDBaseT 5Play™ convergence: High-Definition (HD) Video and Audio, 100BaseT Ethernet, PoH and Control (Bidirectional IR/RS-232 pass-through)
- Supports pass-through of HD audio formats: LPCM 2/5.1/7.1CH, Dolby Digital 2/5.1CH, Dolby Digital Plus, Dolby TrueHD, Dolby Atmos and DTS-HD Master Audio
- Supports optical sampling rate up to 96kHz
- Supports Ethernet network connection
- Supports external analog and digital audio transmission
- Supports ARC function from HDMI out to both HDMI in and optical output
- Supports RS-232 baud rate from 110~115200bps
- US 2 gang wall-plate design and installation friendly

System Requirements

Input source equipment such as DVD/Blu-ray player, host PC/Laptop and HDMI equipped output display (TV or monitor) with amplifier or active speakers.



Transmitter Front Panel

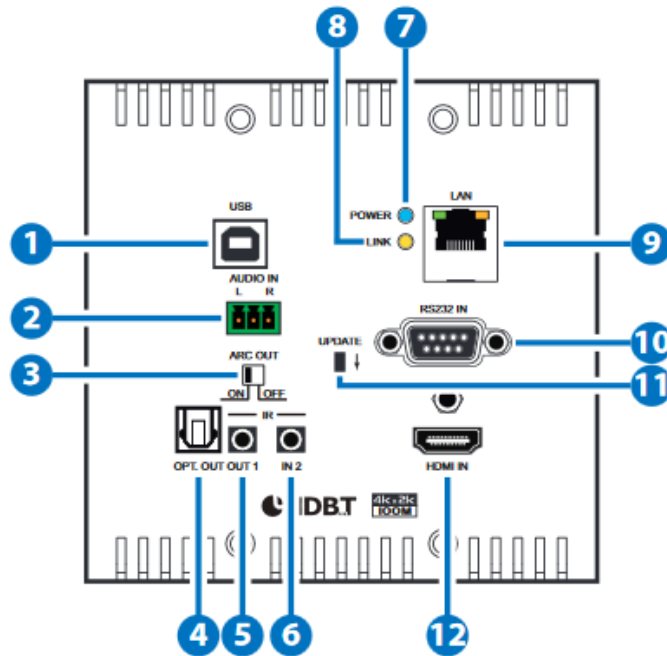

1. USB:

Connect from PC or Laptop for data transmit to or control from the Receiver's USB slots.

2. AUDIO IN L/R:

Connect with audio source equipment such as PC or CD player with 3-pin Relay cable for audio signal sending to Receiver's AUDIO OUT L/R.

3. ARC OUT OFF/ON SWITCH:

Switch this dip switch to allows ARC (Audio Return Channel) function to be activate or not. Switch to OFF to disable ARC function. Switch to ON allows Receiver's HDMI output or Optical in audio to be routed back and output to both HDMI IN and Optical OUT on the transmitter side.

Note: When ARC switch to ON, depending on the connected devices of the HDMI OUT & Optical in from Receiver and the connected device of the HDMI In & Optical Out at the Transmitter the audio format and behavior may be varied, the ARC input/output transmission distance may be varied too, it is suggested to use cable within 2 meters long to ensure the best audio quality.

4. OPT. OUT:

Connect to speaker for audio signal output from Receiver's OPTICAL IN or ARC from HDMI out.

5. IR OUT 1:

Connect to the supplied IR Blaster Cable for IR signal transmission. Place the IR Blaster in direct line-of-sight of the equipment to be controlled.

6. IR IN 2:

Connect to the supplied IR Extender cable for IR signal reception. Ensure that remote being used is within the direct line-of-sight of the IR Extender.

7 . POWER LED:

When the device is connected with power supply the LED will illuminate.

8 . LINK LED:

This LED will illuminate to indicate a successful connection between Transmitter and Receiver, when it blink irregularly it represent the link error or when not illuminate it means no link with Receiver.

9 . LAN:

Connect to internet or network service system to this slot or to the LAN port slot of the Receiver side for a total sharing rate of 100Mbps withing the link. The yellow LED will illuminate to represent the link with Transmitter is steady, when it blink irregularly it represent the link error or when not illuminate it means no link with Receiver. The green LED will illuminate to represent the Ethernet speed is with 100Mbit/s.

10 . RS-232 IN:

Connect to a PC or Laptop D-Sub 9-pin female cable for the transmission of RS-232 commands.

11 . UPDATE:

This is reserved for firmware update use only. Switch this deep switch down for firmware update use, under normal operation, leave the switch up. Update procedure may be done from the same RS-232 port for both Transmitter and Receiver.

12 . HDMI IN:

Connect to HDMI source equipment such as a DVD or Blu-ray player.

Note: When ARC switch to ON, this slot will be receiving signal from Receiver and will not be able to send signal out to Receiver.

Transmitter Rear Panel

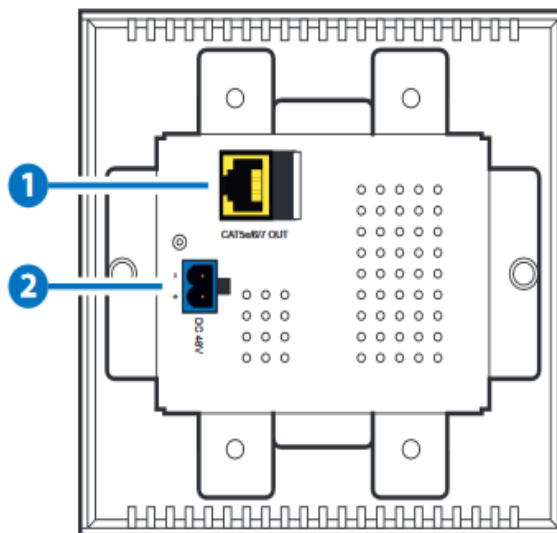

1. CAT5e/6/7 OUT:

Connect to the Receiver unit with CAT5e/6/7 cable for transmission of all data signals.

2. DC 48V:

Plug the 48V DC power supply into the unit and connect the adapter to an AC outlet.

Receiver Front Panel

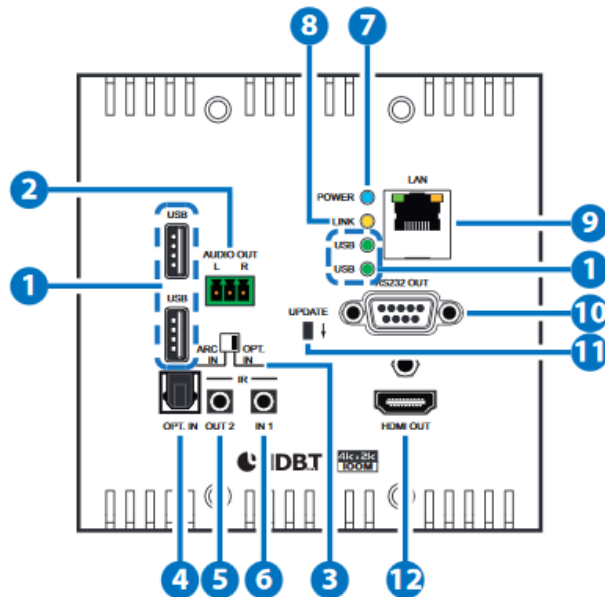

1. USB & LED:

Connect to USB peripheral devices such as printer, keyboard, flash driver or ...etc. for data receiving or sending back to Transmitter and the LED will be illuminated.

2. AUDIO OUT L/R:

Connect to speaker with RCA input for audio signal output.

3. ARC IN/OPT. IN SWITCH:

Switch this dip switch to select ARC (Audio Return Channel) from HDMI Out/Optical In. The audio will be routed back and output to both HDMI IN and Optical OUT on the transmitter side.

Note:

When ARC switch to ON, depending on the connected devices of the HDMI OUT & Optical in, the ARC input/output transmission distance may be varied. It is suggested to use cable within 2 meters long to ensure the best audio quality.

4. OPT. IN:

Connect to audio source equipment such as DVD or Blu-ray player for audio signal sending to Transmitter's Optical Out and HDMI IN.

5. IR OUT 2:

Connect to the supplied IR Blaster cable for IR signal transmission. Place the IR Blaster in direct line-of-sight of the equipment to be controlled.

6. IR IN 1:

Connect to the supplied IR Extender cable for IR signal reception. Ensure that remote being used is within the direct lineof- sight of the IR Extender.

7. POWER LED:

This LED will illuminate when the device is connected from Transmitter with PoH power supply.

8. LINK LED:

This LED will illuminate to indicate a successful connection between Transmitter and Receiver, when it blink irregularly it represent the link error or when not illuminate it means no link with Transmitter.

9. LAN:

Connect to internet or network service system to this slot or to the LAN port slot of the Transmitter side for a total sharing rate of 100Mbps withing the link. The yellow LED will illuminate to represent the link with Transmitter is steady, when it blink irregularly it represent the link error or when not illuminate it means no link with Receiver. The green LED will illuminate to represent the Ethernet speed is with 100Mbit/s.

10. RS-232 OUT:

Connect to the device that is to be controlled via D-Sub 9-pin male cable by RS-232 commands.

11. UPDATE:

This is reserved for firmware update use only. Switch this deep switch down for firmware update use, under normal operation, leave the switch up. Update procedure may be done from the same RS-232 port for both Transmitter and Receiver.

12. HDMI OUT:

Connect to HDMI source equipment such as a DVD or Blu-ray player.

Note: When ARC IN is selected, depending on the connected device the audio behavior, format & cable distance may be varied. It is suggested to use cable within 2 meters long to ensure the best audio quality.

Receiver Rear Panel

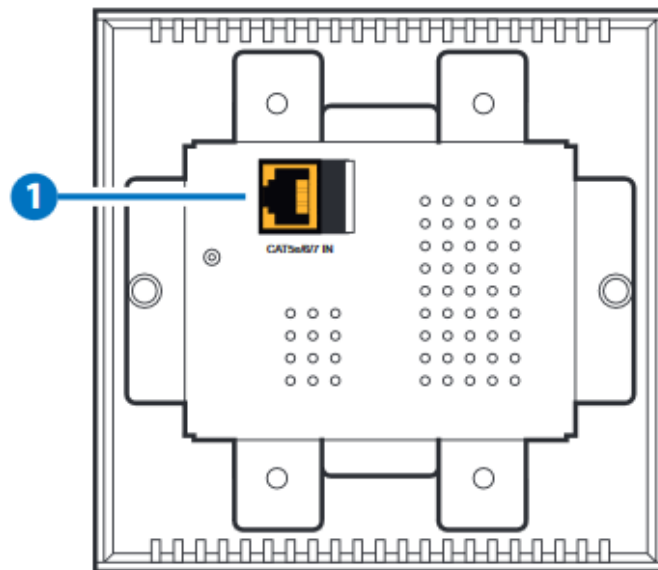

1. CAT5e/6/7 IN:

Connect to the Transmitter unit with CAT5e/6/7 cable for transmission of all data signals.

IR Cable Pin Assignment

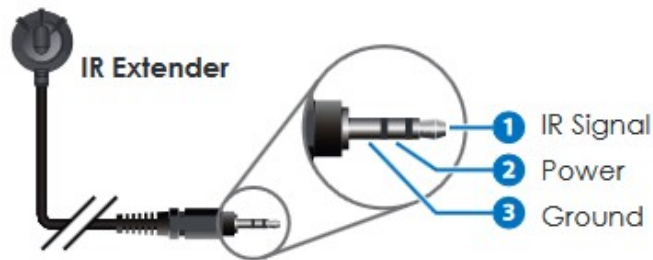
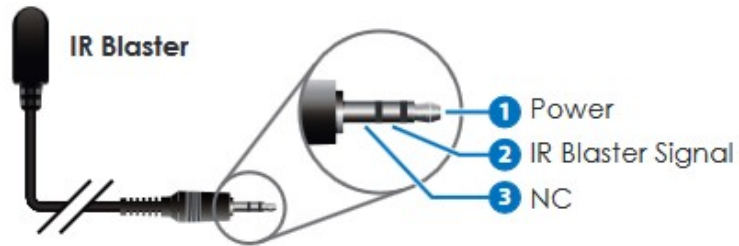

D-Sub 9-Pin Assignment

Pin	Assignment
1	N/C
2	Tx/Rx
3	Rx/Tx
4	N/C
5	GND
6	N/C
7	N/C
8	N/C
9	N/C

Specifications

Video Bandwidth	340 MHz/10.2 Gbps
Transmitter	
Input Ports	1×HDMI, 1×USB, 1×L/R (Terminal Block), 1×LAN,1×IR Extender, 1×RS-232
Output Ports	1×CAT5e/6/7, 1×Optical, 1×IR Blaster
Receiver	
Input Ports	1×CAT5e/6/7, 1×Optical, 1×IR Extender
Output Ports	1×HDMI, 2×USB, 1×L/R (Terminal Block), 1×LAN, 1×IR Blaster,1×RS-232
IR Frequency	30~50 kHz
Baud Rate	Up to 115200 bps
Power Supply	48V/0.83A DC (US/EU standards, CE/FCC/ UL certified)
ESD Protection	Human Body model: ± 8kV (air-gap discharge) ± 4kV (contact discharge)
Dimensions	125 mm (W)×127 mm (D)×41.8 mm (H)TX 125 mm (W)×127 mm (D)×41.8 mm (H)RX
Weight	266 g/TX, 264 g/RX
Chassis Material	Metal
Silkscreen Color	White
Operating Temperature	0 °C~40 °C/32 °F~104 °F
Storage temperature	-20 °C~60 °C/-4 °F~140 °F
Relative Humidity	20~90% RH (no condensation)
Power Consumption	21.34 W

Connection Diagram

