

HDMI/Audio over CAT5e/6 /7 Extender with 48V PoE # 15373



Operation Manual

Introduction

This HDMI and Audio over Single CAT5e/6/7 Transmitter and Receiver set can send uncompressed audio/video along with controls, IP and USB data over a single run of CAT5e/6/7 cable up to 100m. It has the added benefit of control through the built-in RS-232 and IR ports and a bidirectional LAN serving connection. There is a bidirectional digital audio capability that gives users the convenience of an additional audio connection. This system also allows the connection of any USB host, enabling a USB connection to up to 2 USB ports, giving the Receiver the ability to act like a USB hub. The 48V PoE design can power the Receiver (PD) from the Transmitter (PSE), eliminating the need for a separate power supply for the Receiver.

Features

- Supports HDBaseT 2.0 specification supporting over a single CAT6/7 cable up to 100m/328ft and CAT5e cable up to 90m/295ft
- Fully compliant with HDMI 1.4, and compatible with HDMI 2.0 (4K2K 60Hz with 4:2:0)
- Receiver features 2 USB 2.0 ports
- HDMI (with 3D & 4Kx2K support), HDCP and DVI compliant
- HDBaseT 5Play™ convergence: High-Definition (HD) Video and Audio, 100BaseT Ethernet, PoE and Control (Bidirectional IR/RS-232 pass-through)
- Supports pass-through of audio formats: LPCM2/5.1/7.1CH, Dolby Digital 2~5.1Ch, Dolby Digital Plus, Dolby TrueHD and DTS-HD Master Audio
- Supports 10/100 Ethernet network connection
- Bidirectional LAN and external digital audio capability
- Supports RS-232 baud rate from 110~115200bps

Applications

- 48V PoE from Transmitter (PSE) to Receiver (PD)
- Household entertainment extending and control
- Lecture room display and control
- Showroom display and control
- Meeting room presentation and control
- Classroom display and control

System Requirements

Input source equipment such as DVD/Blu-ray player, host PC/Laptop and HDMI equipped output display (TV or monitor) with amplifier or active speakers.



Operation Controls and Functions

Transmitter Front Panel

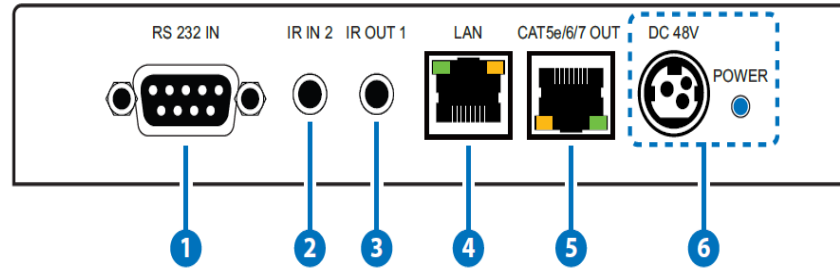

1. RS-232 IN

Connect to a PC or Laptop with D-Sub 9-pin female cable for the transmission of RS-232 commands.

2. IR IN 2

Connect to the supplied IR Extender cable for IR signal reception. Ensure that remote being used is within the direct line-of-sight of the IR Extender.

3. IR OUT 1

Connect to the supplied IR Blaster Cable for IR signal transmission. Place the IR Blaster in direct line-of-sight of the equipment to be controlled.

4. LAN

Connect to an internet or network connection.

5. CAT5e/6/7 OUT

Connect to the Receiver unit with a single CAT5e/6/7 cable for transmission of all data signals. The yellow LED will illuminate to represent the link from Receiver is steady, when it blink irregularly it represent the link error or when not illuminate it means no link with Receiver. The green LED will illuminate to represent the HDMI signal contents HDCP signal.

6. DC 48V & POWER LED

Plug the 48V DC power supply into the unit and connect the adaptor to an AC outlet and the LED will illuminate.

Transmitter Back Panel

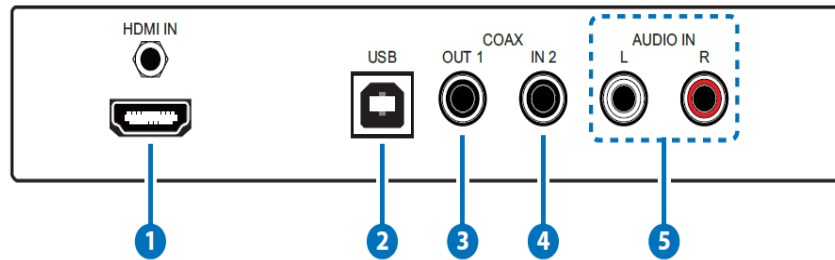

1. HDMI IN

Connect to HDMI source equipment such as a DVD or Blu-ray player.

2. USB

Connect from PC or Laptop for data transmit to or control from the Receiver's USB slots.

3. COAX OUT 1

Connect to speaker with coaxial input for audio signal output from Receiver's COAX IN 1.

4. COAX IN 2

Connect to audio source equipment such as DVD or Blu-ray player for audio signal sending to Receiver's COAX OUT2.

5. AUDIO IN L/R

Connect with audio source equipment such as PC or CD player for audio signal sending to Receiver's AUDIO OUT L/R.

Receiver Front Panel

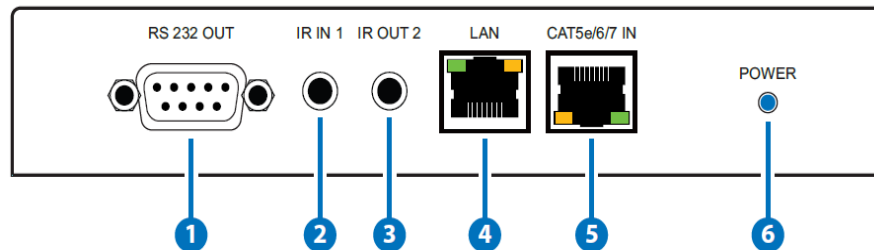

1. RS-232 OUT

Connect to the device that is to be controlled (via D-Sub 9-pin male cable) by RS-232 commands.

2. IR IN1

Connect to the supplied IR Extender cable for IR signal reception. Ensure that remote being used is within the direct line-of-sight of the IR Extender.

3. IR OUT 2

Connect to the supplied IR Blaster cable for IR signal transmission. Place the IR Blaster in direct line-of-sight of the equipment to be controlled.

4. LAN

Connect to a PC or Laptop to the internet or network connection.

5. CAT5e/6/7 IN

Connect to the Transmitter unit with a single CAT5e/6/7 cable for transmission of all data signals. The yellow LED will illuminate to represent the link from Receiver is steady, when it blink irregularly it represent the link error or when not illuminate it means no link with Receiver. The green LED will illuminate to represent the HDMI signal contents HDCP signal.

6. POWER LED

This LED will illuminate when the device is connected with power supply.

Receiver Back Panel

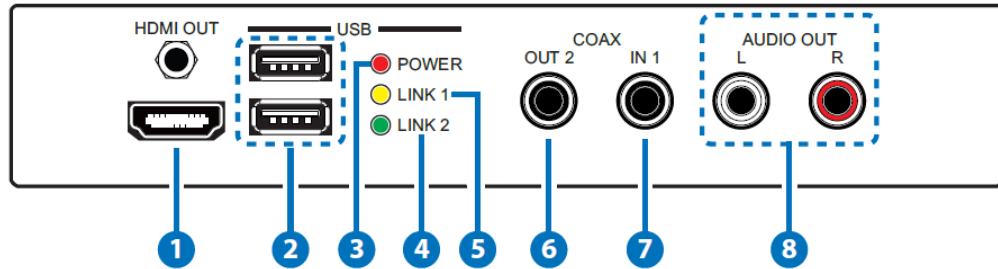

1. HDMI OUT

Connect to a HDMI equipped TV/monitor for display of the HDMI input source signal.

2. USB

Connect to USB peripheral devices such as printer, keyboard, flash driver or ...etc. for data receiving or sending back to Transmitter.

3. POWER LED

This LED will illuminate when device is connected with USB power supply.

4. LINK 2

This LED will illuminated when the lower USB slot is connected with signal activated.

5. LINK 1

This LED will illuminated when the upper USB slot is connected with signal activated.

6. COAX OUT 2

Connect to speaker with coaxial input for audio signal output from Transmitter's COAX IN 2.

7. COAX IN 1

Connect to audio source equipment such as DVD or Blu-ray player for audio signal sending to Transmitter's COAX OUT1

8. AUDIO L/R OUT

Connect to speaker with RCA input for audio signal output.

**IR Cable
Pin Assignments**

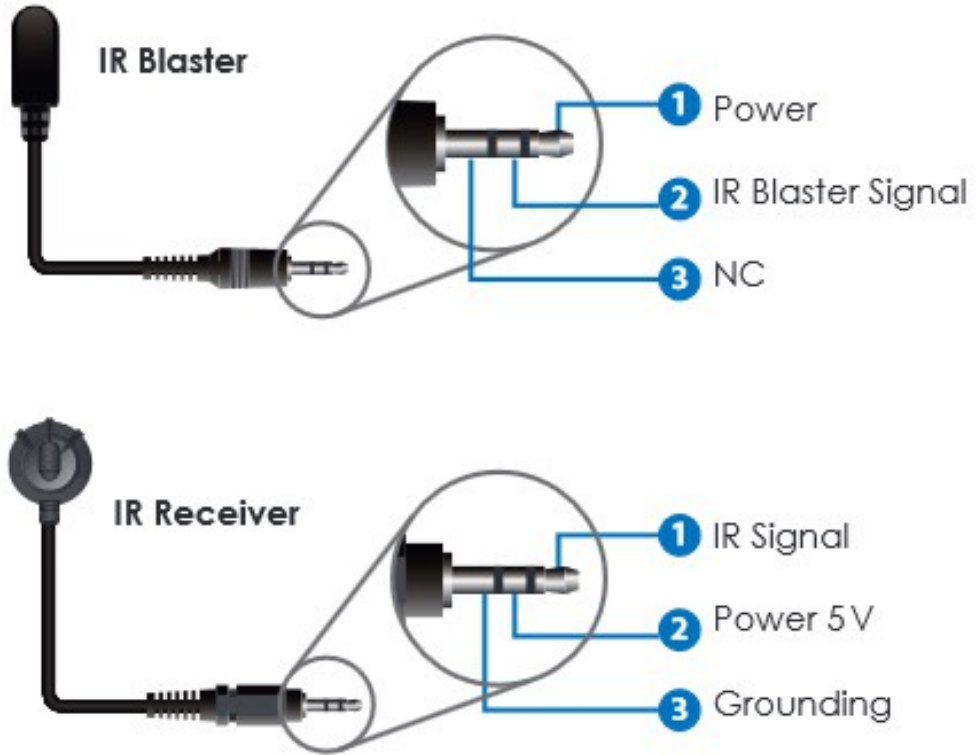

**D-Sub 9 Pin
Definition**

PIN	DEFINE TX/RX
1	N/C
2	TxD/RxD
3	RxD/TxD
4	N/C
5	GND
6	N/C
7	N/C
8	N/C
9	N/C

Specifications

Video Bandwidth	340MHz/10.2Gbps
Transmitter	
Input Ports	1 x HDMI 1 x LAN, 1 x RS-232, 1 x IR, 1 x USB, 1 x Coaxial, 1 x L/R
Output ports	1 x CAT5e/6/7, 1 x IR 1 x Coaxial
Receiver	
Input Ports	1 x CAT5e/6/7, 1 x IR, 1 x Coaxial
Output Ports	1 x HDMI, 1 x RS-232, 1 x LAN, 1 x Coaxial, 1 x IR, 2 x USB
IR Frequency	30~50kHz
Baud Rate	Up to 115200bps
Power Supply	48VDC/0.83A (US/EU standards, CE/FCC/ UL certified)
ESD Protection	Human body model: ±8kV (air-gap discharge) ±4kV (contact discharge)
Dimensions	160mm (W) x 130mm (D) x 30mm (H)/ Jacks Excluded 165mm (W) x 141mm (D) x 33mm (H)/ Jacks Included
Weight	624g/Tx, 618g/Rx
Chassis Material	Metal
Silkscreen Color	Black
Operating Temperature	0°C~40°C / 32°F ~ 104°F
Storage temperature	-20°C~60°C / -4°F ~ 140°F
Relative Humidity	20~90% RH (no condensation)
Power Consumption	19w

Connection Diagram

